



WARMING
S Y S T E M S

Electric Floor Warming Systems Installation and Operation Instructions

Mat Heating Systems
and
Cable Heating Systems



UL LISTED for USA and Canada

WARMING SYSTEMS INC.
7706 Industrial Dr. Unit D Spring Grove, IL 60081
1-800-663-7831

sales@warmingsystems.com

warmingsystems.com



The electric floor warming systems manufactured by Warming Systems Inc. are designed for interior floor applications, supplying 12 watts/square foot. They cannot be used for exterior snowmelt or ceiling heating applications. Install below ceramic or porcelain tile, stone or brick floors by embedding in ¼” to ½” mortar. This heating system can also be installed under engineered wood, vinyl, laminate, or carpet floor coverings by completely embedding the heating mat/cable in a self-leveling mortar ¼” to ½” thick. Use only polymer modified cement based mortars. This heating system should be installed on concrete or concrete backer board.

System Specifications:

Listing: UL LISTED for U.S. and Canada under UL 1673, UL File # E310385

Controls: Must be controlled by floor sensing thermostat.

Voltage: 120 VAC, 240 VAC, 1-phase

Watts: 12 W/sq. ft. (41 Btu/h/sq. ft.)

Maximum circuit load: 15A

Maximum circuit overload protection: 20 A breaker

Application: Indoor floor heating application only. (-X indicates CUL Listing for this application) Suitable for installation in a shower area. (-W indicates CUL Listing for wet location) Only embed in polymer modified cement based mortar.

Minimum bend radius: 1 inch

Maximum exposure to temperature: 194°F (90°C)

Minimum installation temperature: 50°F (10°C)

INSTALLATION CAUTIONS:

NEVER: NEVER CUT THE RED HEATING ELEMENT

NEVER: bang a trowel on the heating element

NEVER: overlap heating elements, it may cause overheating

NEVER: install heating elements in adhesives or glues intended for vinyl tile or other laminate flooring. It must be embedded in cement based mortar

NEVER: install under cabinets or other permanent objects

NEVER: install under carpet, wood, vinyl, or other non-masonry flooring without ¼” to ½” thick thin-set or self-leveling mortar

NEVER: remove the nameplate label at the end of the cold lead

ALWAYS: pay attention to voltage and amperage requirements

ALWAYS: continue to confirm the ohm resistance across the heating system remains the same before, throughout, and after the installation

ALWAYS: make sure all electrical work is done by qualified persons in accordance with local building and electrical codes, and the National Electrical Code (NEC), especially Article 424, of the National Electric Code, ANSI/NFPA 70. If in Canada must meet the requirements of the Canadian Electrical Code (CEC) Article 62.

Part A: Test the floor heating system:



Confirm the Ohm resistance between the Black and White cold lead wires are within the resistance range on the system's white label.



Confirm there is no short to ground in the system by measuring the resistance between the ground wire and the Black/White cold leads. The reading on the ohm meter should be “open” or “infinite” resistance.

When testing the ohms of the floor sensor please note that the resistance is between 8,000 and 12,000 ohms. If possible, dial your multi-meter to 20K before testing the sensor wire.



Part B: Thermostat and Electrical Requirements:

Only a certified electrician who is familiar with electrical installation codes and practices can connect the floor heating system. All wiring must comply with the specifications in the US National Electric Code and all local electrical regulations and standards.

WARNING – RISK OF ELECTRIC SHOCK AND FIRE. DAMAGE TO SUPPLY CONDUCTOR INSULATION MAY OCCUR IF CONDUCTORS ARE ROUTED LESS THAN 2 INCHES (51mm) FROM THIS HEATING PRODUCT. REFER TO INSTALLATION INSTRUCTIONS FOR RECOMMENDED MEANS OF ROUTING SUPPLY CONDUCTORS.

AVERTISSEMENT - RISQUE D'ÉLECTROCUTION ET D'INCENDIE. DES DOMMAGES LIÉS À L'ALIMENTATION DE L'ISOLANT DU CONDUCTEUR PEUVENT SURVENIR SI LES CONDUCTEURS SONT ROUTÉS À MOINS DE 2 POUCES (51mm) DE CE PRODUIT CHAUFFANT. SE RÉFÉRER AUX INSTRUCTIONS D'INSTALLATION POUR LES MOYENS RECOMMANDÉS D'ACHEMINEMENT DE CONDUCTEURS D'ALIMENTATION.

Thermostat: Use a floor sensing thermostat to directly control the floor's temperature where the heating system is installed. A Ground Fault Protection (GFCI), Listed and Certified to UL and Canadian Standards, must be built into the thermostat or located in the breaker panel. The Ground Fault Protection will guard against electrical hazards in case the mat or cable is damaged.

The thermostat should be located on an interior wall, mounted in a 4" square electrical box with a single gang mud ring, and located within reach of the heating system's 10' cold lead. The cold lead must be installed in 1/2" minimum conduit from the bottom plate to the electrical box.

For up to three cables or mats, install a 3/4" conduit from the electrical box down to the floor for installation of the system's power cold leads. Notch the bottom plate so the conduit can be accessed from the floor. The cold lead must be routed through conduit.



Electrical Requirements:

Verify that the electrical circuit powering the heating system has adequate amperage capacity available.

Amperage Draw Requirements:

- 10 square feet requires 1 Amp @ 120 volt.
- 20 square feet requires 1 Amp @ 240 volt.

Example: 50 sq. ft. requires 5 amps @ 120 V

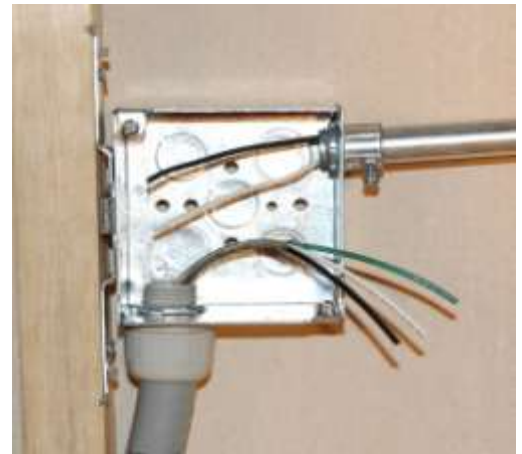

Circuit Breakers and Supply Wire

Mat (s)		Supply Wire (AWG)*	Breaker		
VAC	total amps		qty	type**	rating
120	up to 12 amps	14	1	SP	15 or 20 A
120	up to 15 amps	12	1	SP	20 A
240	up to 12 amps	14	1	DP	15 or 20 A
240	up to 15 amps	12	1	DP	20 A

* Recommended only. Follow local codes for wire gauge size

** SP = single pole, DP = double pole

It may be possible to tap into an existing circuit as long as there is adequate capacity for the heating system(s) and any additional appliances such as a hair dryer.

Part C: Determine where to heat:

Calculate the area to be heated by measuring the square footage making sure not to include permanent objects such as cabinets, fixtures, toilets, sinks, tubs, center islands, etc. The heated area should not extend beyond the room or area in which it originates and also should not be installed in walls or in closets. When installing in a bathroom, keep heating wires about 6” to 8” away from the wax seal on the toilet.

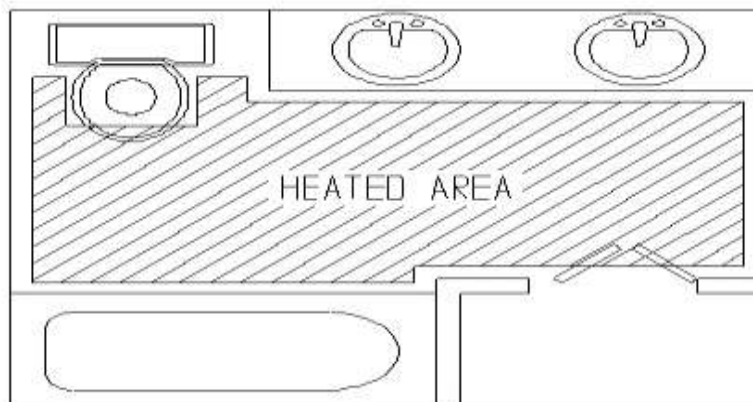



Part D: Installation:

Materials Required for Installation:

- Floor Sensing Thermostat
 - UL LISTED electrical box. 4x4 with single gang “mud ring” cover.
 - Flexible or rigid UL LISTED conduit.
 - 12-gauge or 14-gauge electrical wiring, consult electrical code.
 - Wire nuts
- Make sure the floor is thoroughly cleaned and free from anything that may damage the heating element.
 - Heating element and manufacturer’s splice should be completely embedded in cement based mortar or thin-set.
 - The heating element should be a minimum of 2” from walls and cabinets

MAT INSTALLATION

Fitting Mat: Unroll the floor heating mat making sure the power leads reach the electrical box. Manipulate the mat to fit the desired heating area by using the turning techniques as described below. The white fiberglass mesh may be cut to flip and turn the mat. NEVER CUT THE RED HEATING ELEMENT. The heating element should be kept a minimum distance of 2” apart at all times. The heating cable should never overlap. The heating mat should have a minimal spacing of 2” from walls, cabinets, and permanent objects.



Tape on the mat is double-sided. Peel off liner and affix either side of mat to the floor.

Mat Turn Techniques

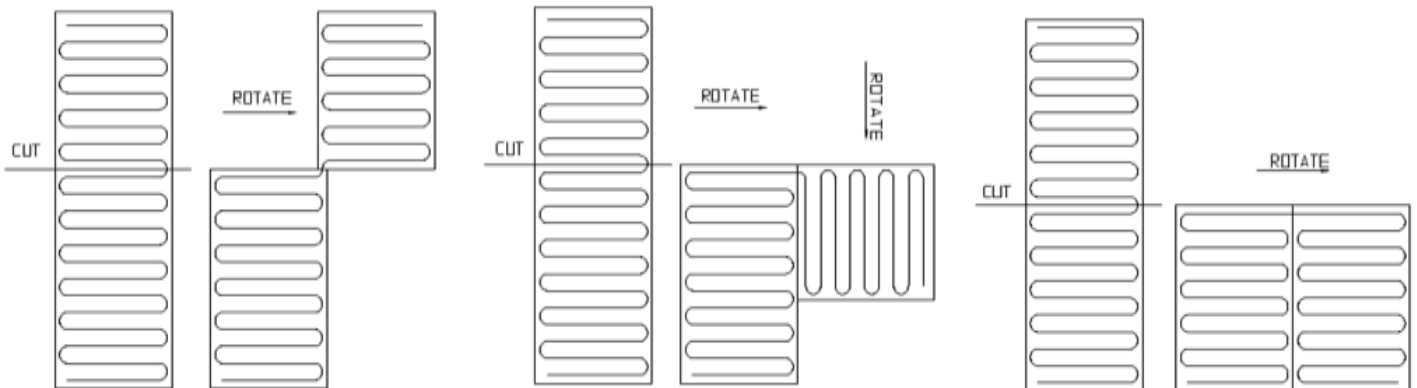

CABLE INSTALLATION

Cable Spacing: Heating cables should be spaced 3” apart across the heated area.

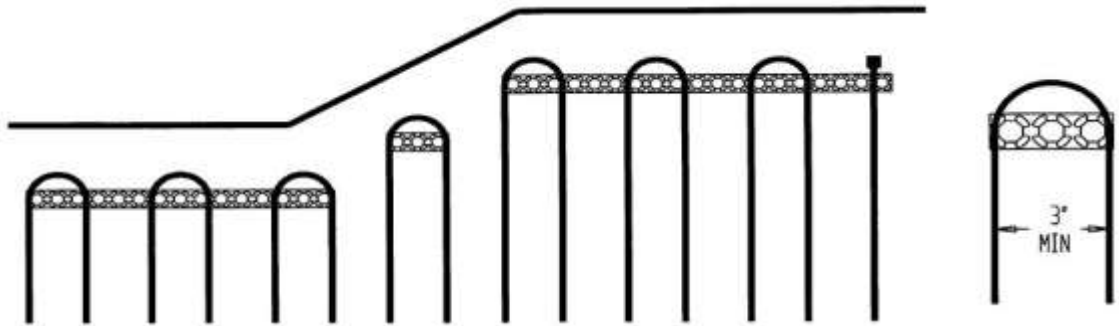

Secure the cable guides according to the planned layout using screws, double sided tape, hot glue or other fasteners approved for use with the given subfloor. The heating element should be spaced 3” apart across the area to be heated. Cable guides should be run perpendicular to heating cables. Attach cable guides no closer than 3” from walls or permanent objects. The heating cables should have a minimum distance of 2” from walls and objects. Spacing between cable guides should not exceed 36” in distance.

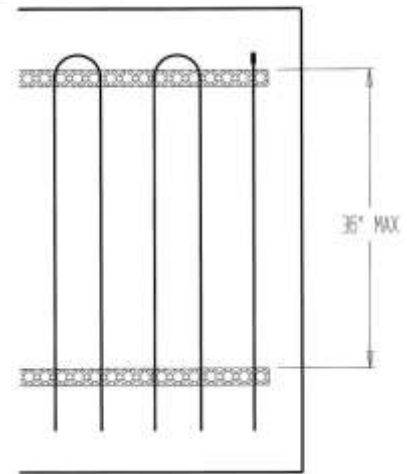

Secure the heating element to cable guides by wrapping the heating element around every 3rd plastic peg. Maintain moderate tension of cable throughout the installation. Do not twist heating element and keep the minimum bending radius of the cable to 1”.



Installation Note: It is important to note that during installation there is a chance that the heating cable may be too long or too short for the heated area. For this reason, it may be necessary to dedicate a small area of the floor where floor warmth is not important in the case the cable is too short. In the case of excess cable, 3” spacing is required and the heating cable must be completely embedded in mortar.

Part E: Shower Installation

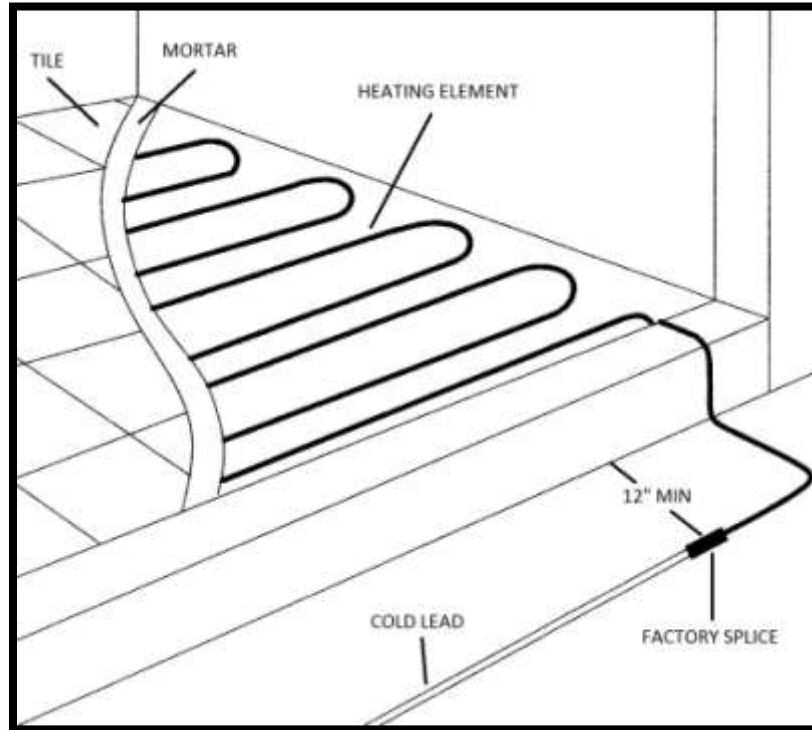

1. Never make a repair splice to heating elements installed in a shower.
2. We recommend that a dedicated mat or cable be installed in the shower. If there is ever a problem with the shower installation, this mat/cable could be disconnected without losing heat to the rest of the floor.
3. Install heating mats using the double-sided tape or hot glue to hold the mat in place. Install heating cable systems using the supplied cable guides. Do not use staples or anything sharp that can damage waterproofing membrane or heating element.
4. If the heating wire must enter the shower area over a curb, secure the wire at the edges in an "s-shaped" curve to guarantee the wire is not pinched or bent sharply when surface coverings are installed. Do not run the heating wire through a non-masonry curb, causing it to overheat.
5. Embed the heating system in a cement based mortar and only install under tile per this instruction manual.
6. The black factory splice between the cold lead and the heating wire must be fully embedded in mortar and located at least 12" away from shower openings and other areas normally exposed to water.
7. The thermostat must be located at least four feet away from shower openings. The thermostat cannot be exposed to water or touched by a person while in the shower area.



Part F: Thermostat Sensor Wire and Power Leads

Power Leads: Feed the cold lead up the conduit to the electrical control box. Mark on the floor where the factory splice will be located. Because this factory splice is thicker than the rest of the cold lead, it may be required to “notch” the floor with a chisel to accommodate this extra thickness. The entire heating mat/cable and factory splice must be completely embedded in mortar.

The Cold Lead has a label with the model number, voltage, and resistance range as well as the marking “FOR INDOOR FLOOR HEATING APPLICATIONS”. This label should be visible during installation. If cold lead is trimmed, re-apply label to end of lead prior to the thermostat installation.

Do not remove this label.

Thermostat Sensor: Run the thermostat sensor up the conduit to the electrical control box. The temperature sensor should be located in-between two heating elements, at least 6” from the edge for the heated area. Test the ohms of the floor sensor prior to installation. Ohm reading on the sensor should be around 8,000 to 12,000. Please make sure meter is on the correct setting to measure this high reading.

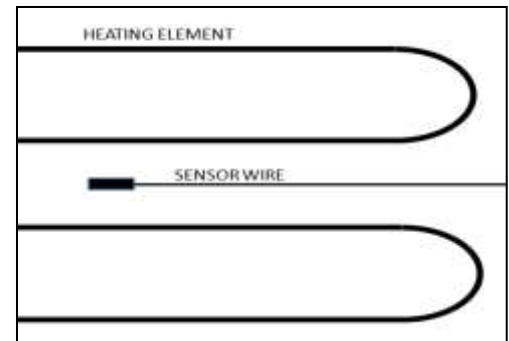

Part G: Floor Covering Installation:

If installing tile or stone floor coverings, a polymer-modified thin-set cement-based mortar and grout is recommended instead of a water-based multi-purpose material. Use the flat side of the trowel and smooth over the heating elements to create a “scratch coat”. Allow scratch coat to dry to protect the heating mat or cable during tile installation then proceed to install the tile per the manufacturer's instructions.

When installing floor coverings other than tile or stone, follow manufacturer’s recommendations. Ensure the mat or cable is first covered with a layer of self-leveling cement based mortar ¼” to ½” thick, letting it cure fully before applying any surface underlayment, floating wood or laminate flooring, carpet, etc. The combined R-values of all floor coverings over the mat should not exceed R-1. Higher R-values will diminish performance. Consult the floor covering manufacturer to verify compatibility with radiant electric heat and to verify R values.



Part H: Final Wiring:

All electrical work should be done by a qualified person, according to all national and local building and electrical codes.

Inspect and remove damaged or defective cables before they are covered or concealed.

Connecting the LINE wires: Connect the “line” connection on the thermostat to the “hot” wire of the incoming power. Connect the “neutral” connection on the thermostat to the “neutral wire” of the incoming power.

Connecting the LOAD wires: Connect the “load” connection on the thermostat to the black wire coming from the floor heating system. Connect the other “load” connection on the thermostat to the white wire coming from the floor heating system.

Connecting the GROUND wire: The bare wire from the floor heating system should be connected to the bare or green ground wire from the incoming power. If using a metal electrical box and metal conduit, attached the ground wire to the electrical box.

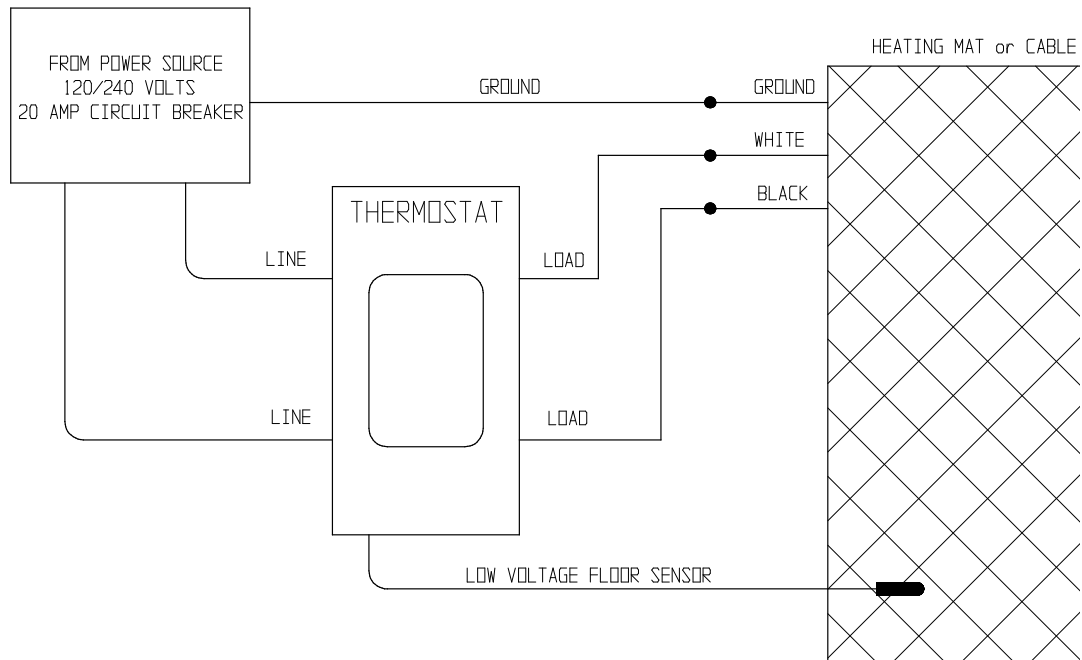

Single Mat or Cable

MULTIPLE UNITS CONNECTED IN PARALLEL

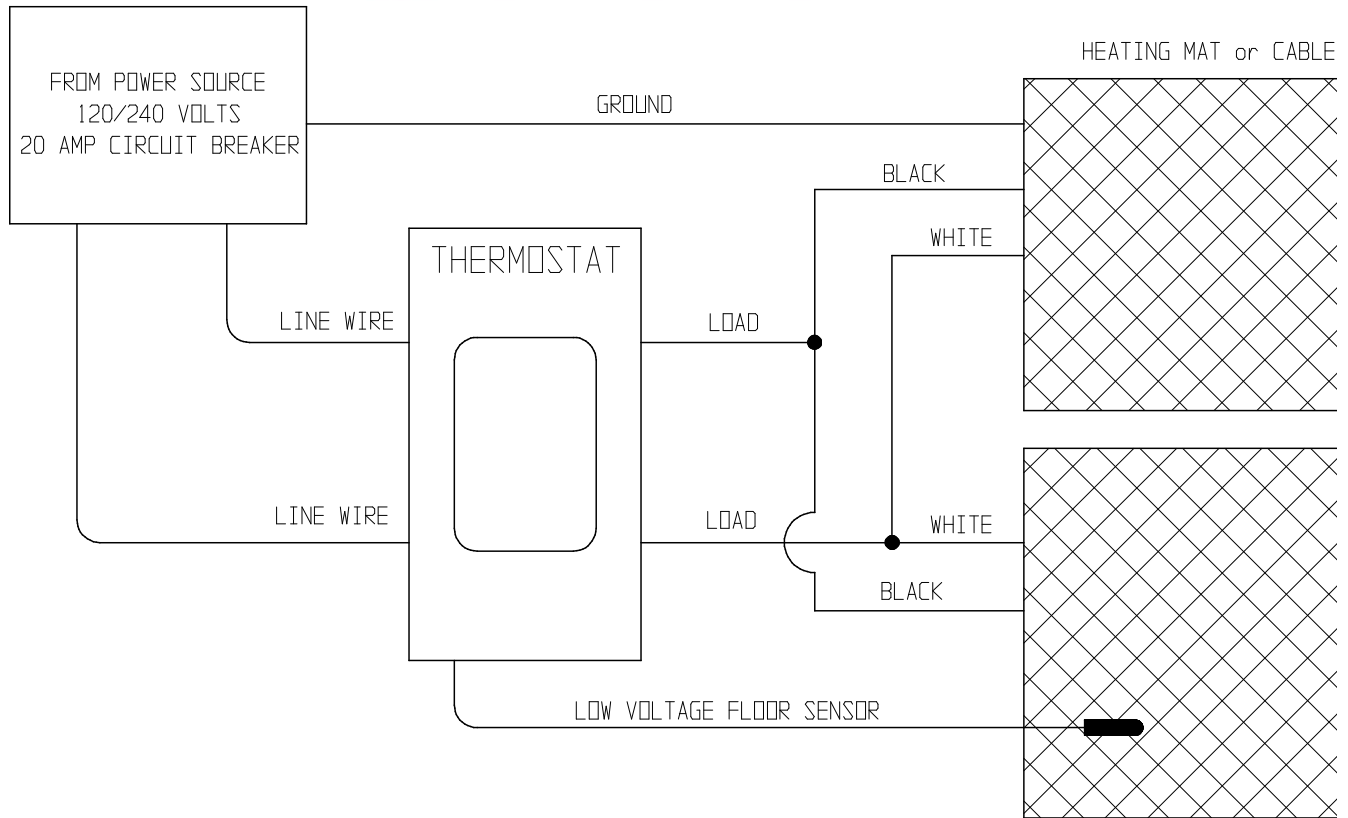

Multiple Mats or Cables

One or more heating systems may be connected together by wiring them in Parallel at the thermostat. Pay close attention not to exceed the amperage capacity of the wiring, thermostat control or the Ground Fault Circuit Interrupter (GFCI).

Part I: Start-up:

After all of the controls are terminated, do not energize the system until the cement materials are fully cured. This may take weeks. Refer to mortar manufacturer's instructions for actual curing time.



OPERATING TIPS

- When first energized, the Warming System may take up to 3 hours to fully warm your floor.
- Energy consumption will vary depending on user preferences, warmer floors require more energy. Other variables including climate, outdoor temperature, and insulation of the room will also affect the energy consumption.
- Energy consumption can be minimized by turning the system off when floor heat is not required.
- Avoid placing thick mats or rugs on the heated floor surface, especially in the area where the floor temperature sensor is located.
- Avoid placing furniture over heated areas.

THIS EQUIPMENT SHALL BE INSTALLED ONLY BY QUALIFIED PERSONNEL WHO ARE FAMILIAR WITH THE CONSTRUCTION AND OPERATION OF THE APPARATUS AND THE RISKS INVOLVED

CET APPAREIL NE DOIT ÊTRE INSTALLÉ QUE PAR DU PERSONNEL QUALIFIÉ QUI CONNAÎT LA CONSTRUCTION ET L'UTILISATION DE L'APPAREIL ET LES RISQUES LIÉS

THE INSTALLATION OF THIS HEATING PRODUCT SHALL BE IN ACCORDANCE WITH THE MANUFACTURER'S INSTRUCTIONS AND THE REGULATIONS OF THE AUTHORITY HAVING JURISDICTION

L'INSTALLATION DE CE PRODUIT DE CHAUFFAGE EST CONFORME AUX INSTRUCTIONS DU FABRICANT ET AUX REGLEMENTS DE L'AUTORITE COMPETENTE